

HYDROTEC®

Technologies



DRAINAGE CHANNELS

2007

OVERVIEW PRODUCTS

	A 125	B 125	C 250	D 400	E 600	F 900
MINI A with slot grating	✓					
MINI B with mesh grating	✓	✓				
TOP 100 A-C with slotted galvanised steel grating and galvanised steel edge protection	✓	✓	✓			
TOP 100 A-C with galvanised mesh grating and galvanised edge protection	✓	✓	✓			
TOP 100 A-C with slotted iron grating and iron edge protection	✓	✓	✓			
MAXI 100 C with ductile iron grating and iron edge protection			✓			
MAXI 100 F with ductile iron grating and iron edge protection			✓	✓	✓	✓
MAXI 150 C with ductile iron grating and iron edge protection			✓			
MAXI 150 F with ductile iron grating and iron edge protection			✓	✓	✓	✓
MAXI 200 C with ductile iron grating and iron edge protection			✓			
MAXI 200 F with ductile iron grating and iron edge protection			✓	✓	✓	✓
MAXI+ 300 E with ductile iron grating and iron edge protection					✓	
HYDROblock 100 / 200 ductile iron one piece drainage					✓	✓

Load classes according to EN 1433



class A 15:
= 15 kN test load

Pedestrian and landscape areas.



class B 125:
= 125 kN test load

Pavements and private car parking areas.



class C 250:
= 250 kN test load

For drainage channelling near to kerbing.



class D 400:
= 400 kN test load

Road surfaces, parking areas.



class E 600:
= 600 kN test load

Areas with high wheel loads, distribution centres.



class F 900:
= 900 kN test load

Special surfaces such as airports.

INDEX

HYDROTEC Channel Systems

Page

Overview products	2
HYDROTEC - The enterprise	4
Advantages at a glance	5

System MINI



System MINI	6
Products MINI 100	7
Installation info	22

System TOP



System	8
Products TOP 100 galvanised slotted grating	9
Products TOP 100 galvanised mesh grating	10
Products TOP 100 with ductile iron grating	11
Installation info	22

System MAXI



System MAXI	12
Products MAXI 100	13
Products MAXI 150	14
Products MAXI 200	15
System MAXI+	16
Products MAXI+ 300	17
Installation info MAXI, MAXI+	23
High security channel MAXI F 1	25

System HYDROblock

System HYDROblock	18
Products HYDROblock 100 / 200	19

Additional information

General installation info	20
Accessories	24

Planning aids

Hydraulic Calculation	26
-----------------------	----

COMPANY OVERVIEW



In what is now more than 35 years of company history a lot has changed at HYDROTEC. However, one thing has remained the same; the focus on improvement. With this philosophy a small business which began in Bremen, under the auspices of Gisbert Brinkschulte, has grown into a worldwide concern. Only so will HYDROTEC continue to grow in the future. The extension of the European Union offers many opportunities. Where HYDROTEC companies are present, we strive to establish ourselves among the leading competitors, all the time remaining true to our principles; supplying high quality products at fair market driven prices, on time, to anywhere in the world.

We want to give answers to questions before they are asked.

We never allow ourselves to sit back, this way we remain innovative.

The HYDROTEC Co. has steadily grown over the years through the constant demands we put on ourselves to extend our product range and client/partner base. We now have a substantial network of sales partners in Germany along with a wide number of Eastern and Western European countries such as France, Hungary and Ireland. Lebanon, the Arab Emirates and South Africa are some of our leading non-European clients.



To optimise our processes, HYDROTEC moved its premises from Bremen to a state of the art building in Wildeshausen in the year 2002. Management, research and development, production, sales and administration now operate under one roof.

It is not only about the business, but also about the people who understand the business.

We as a company, mainly invest in courage, creativity, experience and knowledge - without these characteristics we would not be where we are today. Our employees are chosen, motivated and encouraged to apply their know how on a daily basis. This is achieved with a simple formula; Responsibility. An employee who works solely responsible is motivated and committed to the company. Thus a high level of customer satisfaction is achieved and this in turn broadens the enterprise.



We have a high demands, particularly on the quality of our products.



High quality materials are used in HYDROTEC products. All suppliers are approved and monitored under a strict quality control system designed by our technical team. This system coupled with the knowledge gained from our long years as a leading manufacturer of drainage products enables us to continually improve our production processes.

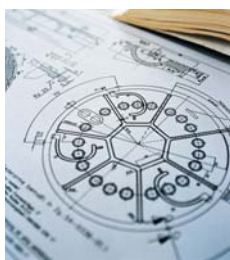

We guarantee a high standard of safety as the HYDROTEC Co. is DIN EN 9001:2000 certified. HYDROTEC also fulfils the requirements of other international standards such as; ON-CERT, EMI and KIWA. Our complete product range is internally and externally quality monitored and approved according to DIN EN 124 and EN 1433. This is naturally in the main interest of our customers. Economics mean change. We view each change first and foremost as an opportunity and do not dwell on just the current market but look to the needs of the future. To satisfy these needs one of the steps we have taken is to appoint new blood to the front line of the family business; Uwe Brinkschulte (Son) and Carsten Schaeffer (Son-in-Law) have joined with Gisbert Brinkschulte (Company Founder) and Member of the Board Dr. Kessler, to continue the success story by adding more impulse and opening new doors of opportunity for the company as a whole.

Advantages at a glance

- all channels are made of fibre-reinforced concrete (concrete strength C35/45)
- all cast iron channels are made of ductile iron according to EN 1563, EN GJS
- liquid-tight in accordance with EN 1433
- frost thawing salt resistant according to EN 1433 and ÖNORM (identification +R = highest frost thawing salt resistancy according to EN 1433)
- internal quality control according to DIN EN 1433
- external quality control according to DIN V 19580
 - through MPA Bremen (test laboratory EN 45001-accredited)
 - and the KIWA according to BRL5070 concrete elements

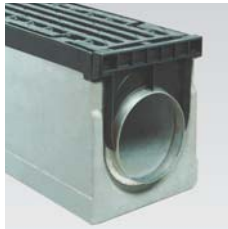

Easy connection to the sewer channel



No „overflow“ thanks to elongated slots



Clean finish for each channel

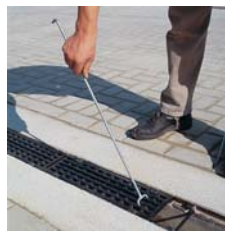

Convenient opening and closing without bending down

Advantages of channels made of fibre-reinforced concrete

Channels made of fibre-reinforced concrete have many advantages compared to polymer concrete.

Fibre-reinforced concrete

- + Foundation effect through compound and design is optimally achieved. The smooth outer surfaces guarantee an optimal derivation of the force tensions in the base.
- + The channels have the same thermal expansion factor as the concrete encasement which prevents breakage during temperature fluctuations.
- + Environmentally sound, natural building material, fully recyclable, environmental requirements are fulfilled without restrictions.
- + Non-flammable

Polymer concrete

- The cavities (V-form) which appear with polymer concrete channels lead to a "knik effect" in the endwalls.
- The different thermal expansions causes tension between the polymer concrete and concrete encasement leading to breakage.
- Waste of not recyclable raw material.
- Flammable

SYSTEM MINI 100

Product description

The MINI 100. The MINI channel is a simple modular system for uncomplicated D.I.Y. installation. The sections are 500 and 1000mm long and easily joined together by means of their practical contoured ends. Each channel section has a precast vertical outlet (DN 100). The overlaid slotted grating and mesh grating provide a neat transition from the channel to the adjoining road surface.

Apart from use in private and leisure areas, the MINI channel is also suitable for pedestrian precincts, courtyards and car parks. The gratings frame into the channels and therefore do not become clamped between the adjoining paving stones. The slotted grating bonds with the concrete body. The use of natural building materials guarantees environmental compatibility.

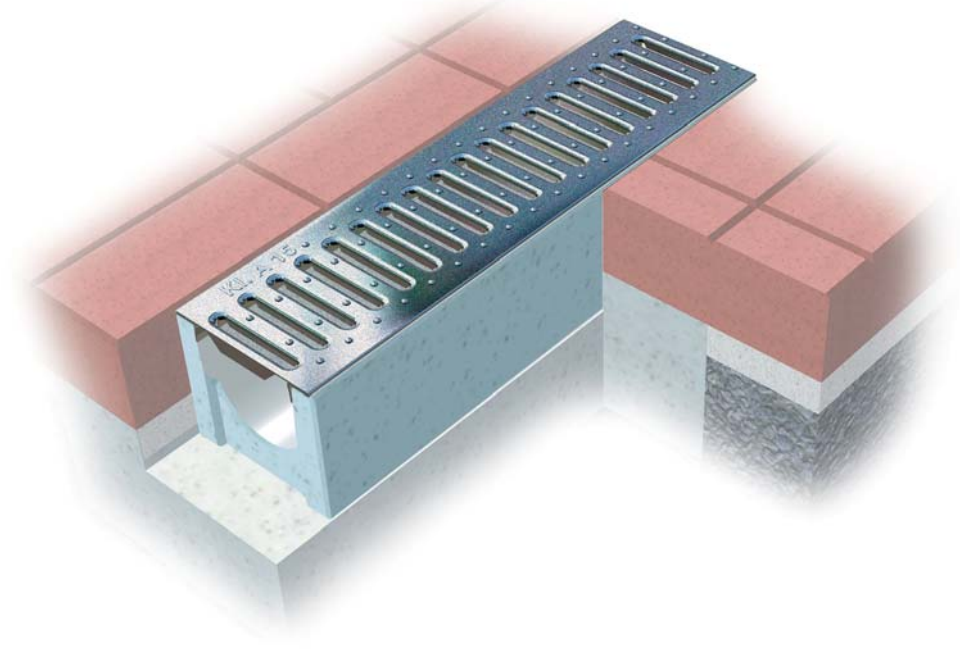

- practical system for easy D.I.Y. installation
- precast vertical outlet in each section
- no gratings clamping between adjoining paving stones
- the overlaid grating replaces edge protection
- precise fitting contoured channel ends for quick joining

Applications

- **Garage drainage**
- **Patio drainage**
- **Drainage of domestic driveways**
- **Forecourt drainage**

SYSTEM MINI 100

MINI A15 with slotted grating



	Code	Weight (kg)	Length mm	Effective height (mm)		Pallet
				Inlet	Outlet	
channel section	64110...					
	120 ...000	24,0	1000	120	120	48
	...005	15,5	500	120	120	96
feed box	...008	29,0	500	363	363	10

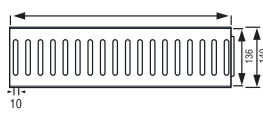
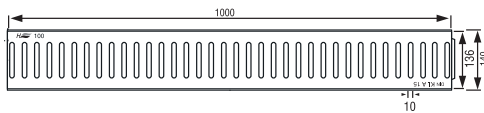

Inlet cross-section 280 cm²/m

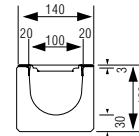
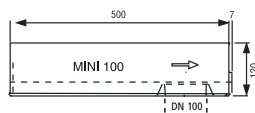
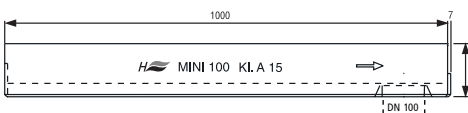

MINI B125 with galvanised mesh grating



	Code	Weight (kg)	Length mm	Effective height (mm)		Palet
				Inlet	Outlet	
channel section	64120...					
	120 ...000	24,0	1000	120	120	48
	...005	15,5	500	120	120	96
feed box	...008	29,0	500	363	363	10

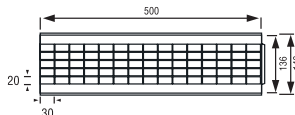
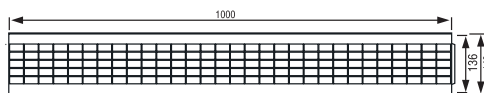

Inlet cross-section 848 cm²/m

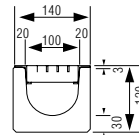
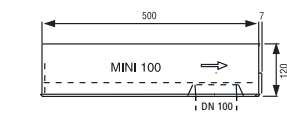
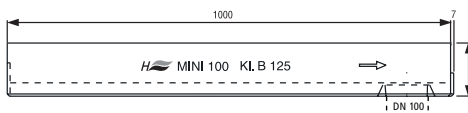

Accessories MINI A and B

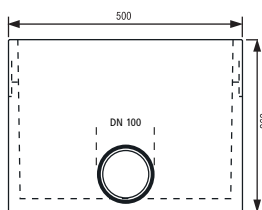

feed box



end piece
item-no.: 7001600



pipe joint DN 100
item-no.: 7002100

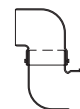

foul air trap DN 100
item-no.: 7003100

Example of installation page 20

SYSTEM TOP 100

Product description

The low-priced and multifunctional TOP-system covers the load classes A15 up to C250, with different coverings such as galvanised slotted and mesh gratings as well as ductile iron gratings. All channel sections are supplied with matching gratings pre-assembled.

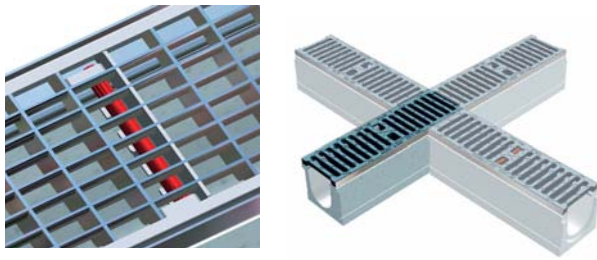

Special section as elbow piece, T-piece or crosspiece.

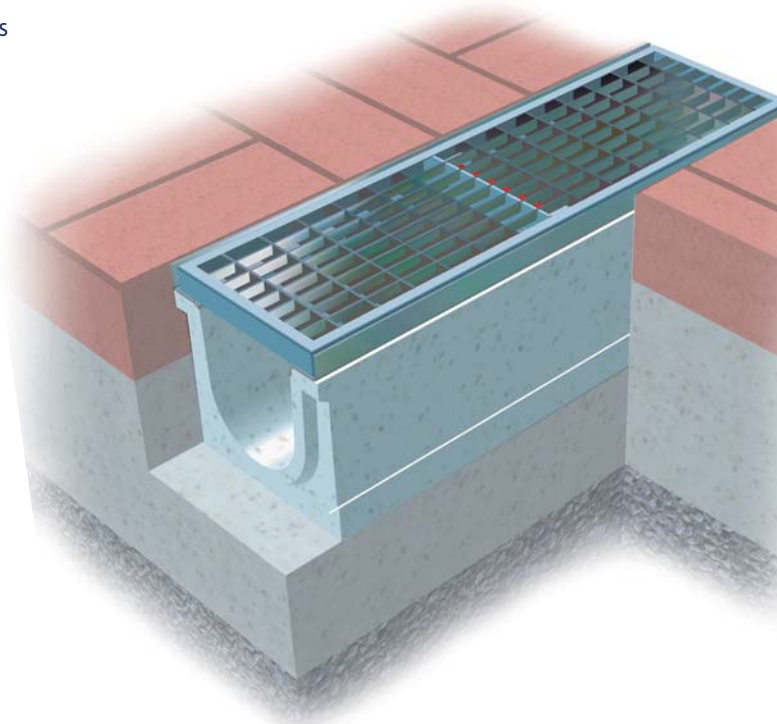

- ductile iron gratings with galvanised slotted grating or galvanised mesh grating
- patented screwless grating locking system
- galvanised steel edge protection
- channel made of fibre-reinforced concrete C35/45
- precise fitting connecting profiles
- secure anchoring thanks to longitudinal rib
- precast base for vertical outlet DN 100/150
- secure rebated joint
- EN 1433, DIN V 19580, Typ M

Application

- Cycle paths and pedestrian walkways
- School playgrounds
- Car parking decks

Modular system

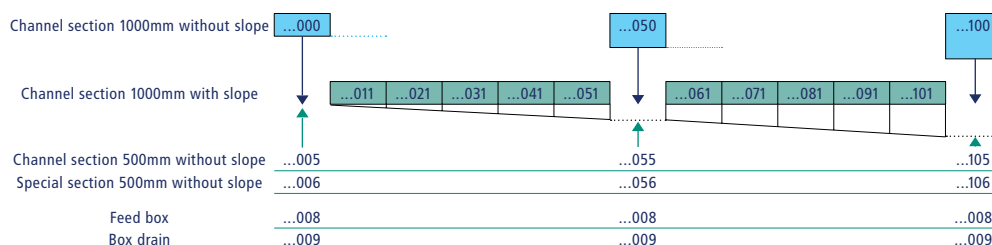

SYSTEM TOP 100

TOP 100 A 15 - C 250 with galvanised slotted grating



		Code A 15	Weight kg	Code C 250	Weight kg	Length mm	Effective height (mm)		Pallet
							Inlet	Outlet	
		63210...		63430...					
Basic section	160	...000	32,0	...000	34,5	1000	160	160	24
		...005	16,0	...005	17,5	500	160	160	48
Special section		...006	15,5	...006	16,5	500	160	160	48
Basic section	185	...050	37,5	...050	40,0	1000	185	185	24
		...055	19,0	...055	20,5	500	185	185	48
Special section		...056	18,0	...056	19,5	500	185	185	48
Basic section	210	...100	43,5	...100	46,5	1000	210	210	24
		...105	21,0	...105	22,5	500	210	210	48
Special section		...106	20,0	...106	21,5	500	210	210	48
Feed box	500	...008	45,5	...008	47,0	500	500	500	10
Section with slope	160 - 185	...011	33,5	...011	36,5	1000	160	165	24
		...021	34,5	...021	37,0	1000	165	170	24
		...031	35,5	...031	38,0	1000	170	175	24
		...041	36,0	...041	38,5	1000	175	180	24
		...051	37,0	...051	39,5	1000	180	185	24
Section with slope	185 - 210	...061	38,0	...061	40,5	1000	185	190	24
		...071	39,5	...071	42,0	1000	190	195	24
		...081	40,0	...081	42,5	1000	195	200	24
		...091	42,0	...091	44,5	1000	200	205	24
		...101	43,0	...101	45,5	1000	205	210	24

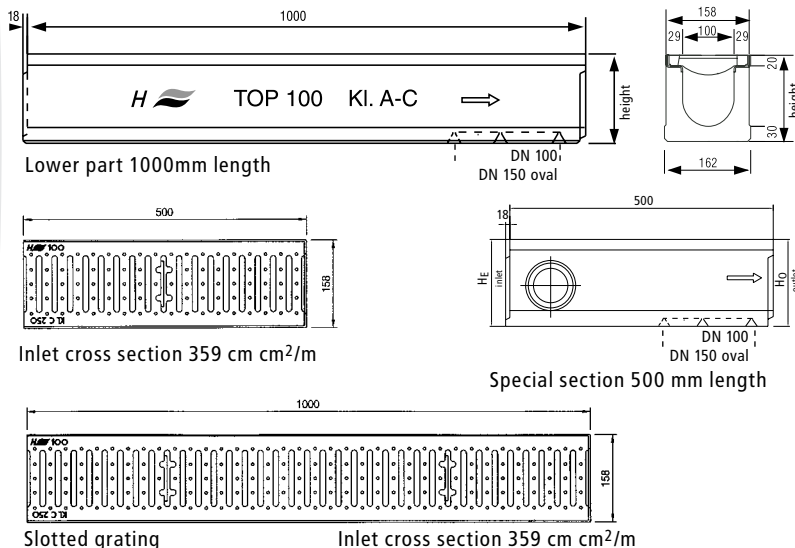

SYSTEM TOP 100

TOP 100 C 250 with galvanised mesh grating



	Code C 250	Weight kg	Length mm	Effective height (mm)		Pallet	
				Inlet	Outlet		
63230...							
Basic section	160	...000	34,0	1000	160	160	24
		...005	17,0	500	160	160	48
Special section		...006	16,0	500	160	160	48
Basic section	185	...050	39,5	1000	185	185	24
		...055	20,0	500	185	185	48
Special section		...056	19,0	500	185	185	48
Basic section	210	...100	45,5	1000	210	210	24
		...105	22,0	500	210	210	48
Special section		...106	21,0	500	210	210	48
Feed box	500	...008	47,0	500	500	500	10
Channel section with slope	160 - 185	...011	35,5	1000	160	165	24
		...021	36,5	1000	165	170	24
		...031	37,5	1000	170	175	24
		...041	38,0	1000	175	180	24
		...051	39,0	1000	180	185	24
Channel section with slope	185 - 210	...061	40,0	1000	185	190	24
		...071	41,5	1000	190	195	24
		...081	42,0	1000	195	200	24
		...091	44,0	1000	200	205	24
		...101	45,0	1000	205	210	24

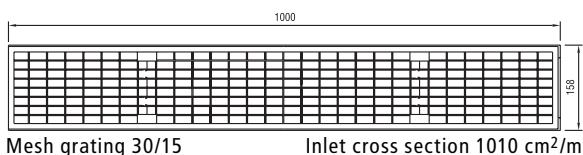
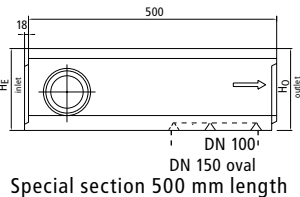
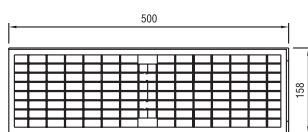
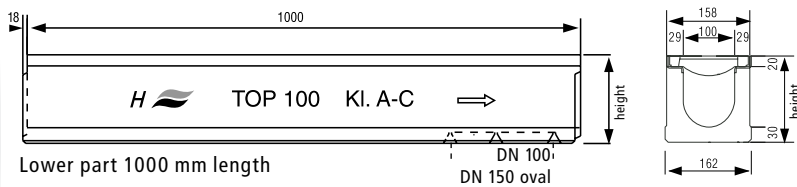
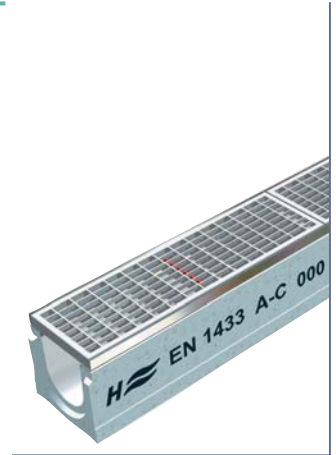

SYSTEM TOP 100

TOP 100 C 250 with ductile iron grating



	Code A 15 - C 250	Weight kg	Length mm	Effective height (mm) Inlet	Effective height (mm) Outlet	Pallet	
63130...							
Basic section	160	...000	45,0	1000	160	160	24
		...005	24,5	500	160	160	48
		Special section	...006	20,5	500	160	160
Basic section	185	...050	49,0	1000	185	185	24
		...055	23,5	500	185	185	48
		Special section	...056	23,5	500	185	185
Basic section	210	...100	54,0	1000	210	210	24
		...105	24,5	500	210	210	48
		Special section	...106	24,5	500	210	210
Feed box	500	...008	49,5	500	500	500	10
Channel section with slope	160 - 185	...011	44,5	1000	160	165	24
		...021	44,5	1000	165	170	24
		...031	44,5	1000	170	175	24
		...041	45,0	1000	175	180	24
		...051	46,0	1000	180	185	24
Channel section with slope	185 - 210	...061	47,0	1000	185	190	24
		...071	48,5	1000	190	195	24
		...081	49,0	1000	195	200	24
		...091	50,5	1000	200	205	24
		...101	52,0	1000	205	210	24

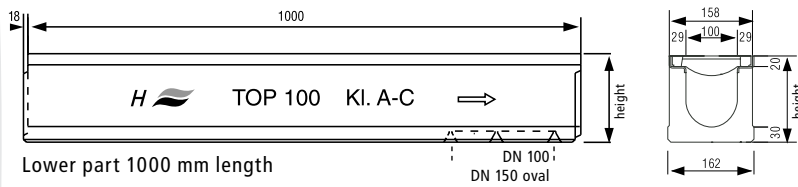

Lower part 1000 mm length

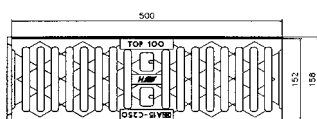

Inlet cross section 564 cm²/m

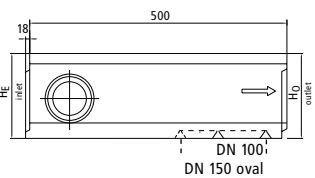

Special section 500 mm length

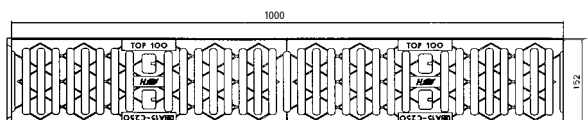

Iron grating

Inlet cross section 564 cm²/m

Accessories for all TOP 100

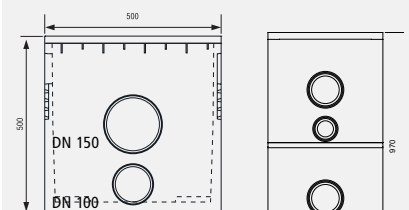

Feed box
with trash bucket

Box drain

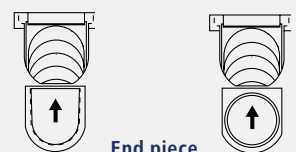

End piece

closed
item-no.: 7001110

with pipe joint DN 100
item-no.: 7001120



Foul air trap DN 100
item-no.: 7003100

SYSTEM MAXI

Product description

The MAXI channel is the optimised heavy-duty channel with some outstanding characteristics. All channels are supplied with matching gratings pre-assembled.

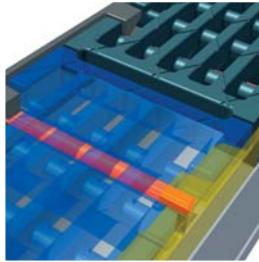

Locking system MAXI



Special section in cross form

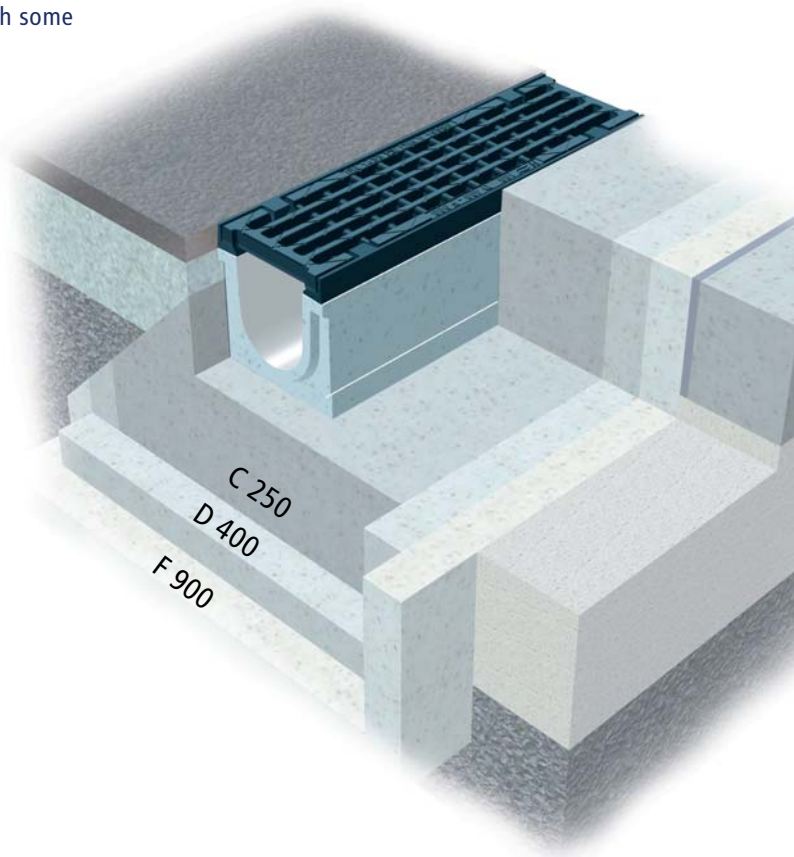

- secure rebated joint
- EN 1433, DIN V 19580, Typ M
- ductile iron grating with longitudinal slots, therefore high water absorption
- longitudinal slots prevent overflowing water
- patented screwless grating locking system
- secure anchored edge protection made of ductile iron
- channel made of fibre-reinforced concrete C35/45
- secure anchoring thanks to longitudinal rib, prevents "outgrowing"
- precise fit connecting profiles
- precast base for vertical outlet at each channel section DN 100/150

Application

- Industrial areas with heavy goods traffic
- Airports / racetracks
- Lorry parking areas / loading and unloading bays
- Cycle paths and pedestrian walkways
- Public traffic routes

Modular system

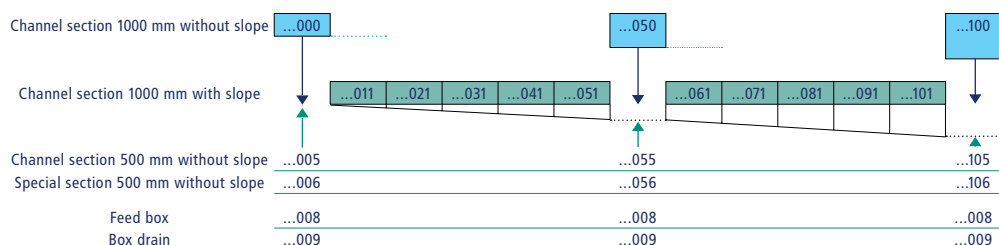

SYSTEM MAXI

MAXI 100 C - F with ductile iron grating and edge protection



	Colde C 250	Weight kg	Code D 400 - F 900	Weight kg	Length mm	Effective height (mm)		Pallet	
						Inlet	Outlet		
	61130...		61160...						
Basic section	160	...000	51,0	...000	51,0	1000	160	160	24
		...005	23,5	...005	23,5	500	160	160	48
Special section		...006	23,0	...006	23,0	500	160	160	-
Basic section	185	...050	55,5	...050	55,5	1000	185	185	24
		...055	26,5	...055	26,5	500	185	185	48
Special section		...056	26,0	...056	26,0	500	185	185	-
Basic section	210	...100	60,5	...100	60,5	1000	210	210	24
		...105	22,5	...105	22,5	500	210	210	48
Special section		...106	21,5	...106	21,5	500	210	210	-
Basic section	235	...150	62,5	...150	62,5	1000	235	235	24
		...155	31,0	...155	31,0	500	235	235	48
Special section		...156	31,0	...156	31,0	500	235	235	-
Basic section	260	...200	65,0	...200	65,0	1000	260	260	24
		...205	32,5	...205	32,5	500	260	260	48
Special section		...206	32,5	...206	32,5	500	260	260	-
Feed box	500	...008	52,0	...008	52,0	500	500	500	10
Channel section with slope	160 - 185	...011	48,5	...011	51,5	1000	160	165	24
		...021	49,5	...021	52,5	1000	165	170	24
		...031	50,5	...031	53,5	1000	170	175	24
		...041	51,0	...041	54,5	1000	175	180	24
		...051	52,0	...051	55,5	1000	180	185	24
Channel section with slope	185 - 210	...061	53,0	...061	56,5	1000	185	190	24
		...071	54,5	...071	57,5	1000	190	195	24
		...081	55,0	...081	58,5	1000	195	200	24
		...091	56,5	...091	59,5	1000	200	205	24
		...101	58,0	...101	60,5	1000	205	210	24



Accessories

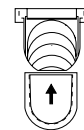

End piece closed
item-no.: 7001110
Height adjustable

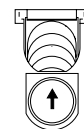

End piece with
pipe joint DN 100
item-no.: 7001120

other accessories page 15/22

Channel section with 2 slotted grating, inlet cross section 512 cm²/m

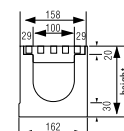
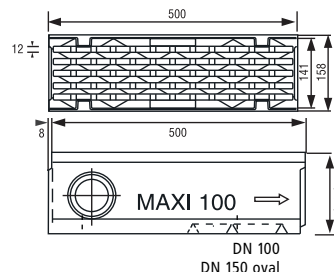
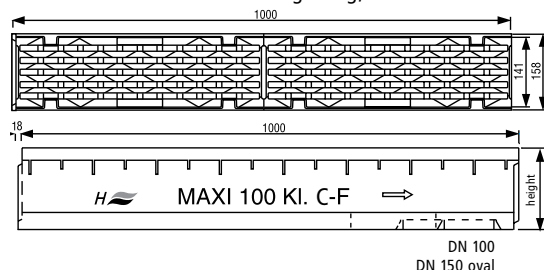

SYSTEM MAXI

MAXI 150 C - F with ductile iron grating and edge protection



		Code C 250	Weight kg	Code D 400 - F 900	Weight kg	Length mm	Effective height (mm)		Pallet
							Inlet	Outlet	
		61530...		61560...					
Basic section	210	...000	77,0	...000	77,0	1000	210	210	20
		...005	36,5	...005	38,4	500	210	210	30
		...006	36,0	...006	36,0	500	210	210	30
Special section	260	...050	84,0	...050	84,0	1000	260	260	20
		...055	40,5	...055	41,3	500	260	260	30
		...056	40,0	...056	40,0	500	260	260	30
Basic section	310	...100	88,0	...100	90,0	1000	310	310	16
		...105	44,5	...105	45,0	500	310	310	30
		...106	44,0	...106	43,0	500	310	310	-
Special section									
Feed box	500	...008	65,0	...008	65,0	500	500	500	10
Channel section with slope	210 - 260	...011	74,5	...011	78,6	1000	210	220	20
		...021	75,8	...021	79,7	1000	220	230	20
		...031	77,4	...031	81,5	1000	230	240	20
		...041	79,5	...041	82,0	1000	240	250	20
		...051	80,0	...051	83,0	1000	250	260	20
Channel section with slope	260 - 310	...061	82,1	...061	84,7	1000	260	270	16
		...071	82,8	...071	88,3	1000	270	280	16
		...081	84,5	...081	86,7	1000	280	290	16
		...091	85,7	...091	89,9	1000	290	300	16
		...101	88,0	...101	90,0	1000	300	310	16



Channel section with 2 slotted grating, inlet cross section 736 cm²/m

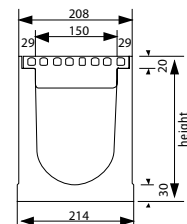
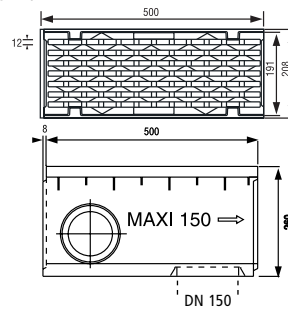
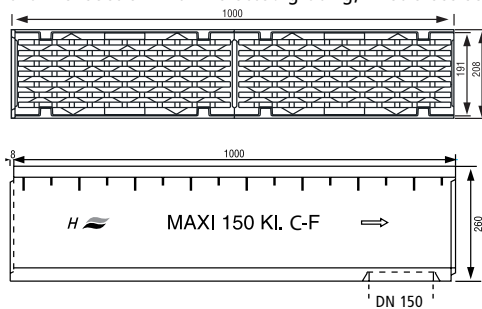

Accessories

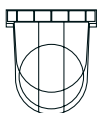

End piece
item-no.:
7001151

SYSTEM MAXI

MAXI 200 C - F with ductile iron grating and edge protection



	Code C 250	Code D 400 - F 900	Weight (kg)	Length mm	Effective height (mm)		Pallet	
					Inlet	Outlet		
Channel section without slope	61230...	61260...						
	310	...050	...050	110,0	1000	310	310	12
		...055	...055	55,0	500	310	310	24
Special section	...056	...056	55,0	500	310	310	-	
Feed box	550-1100	...008	...008	72,0	500	550	550	6
Box drain		...009	...009	144,0	500	1100	1100	5



Channel section with 2 slotted grating, inlet cross section 970 cm²/m

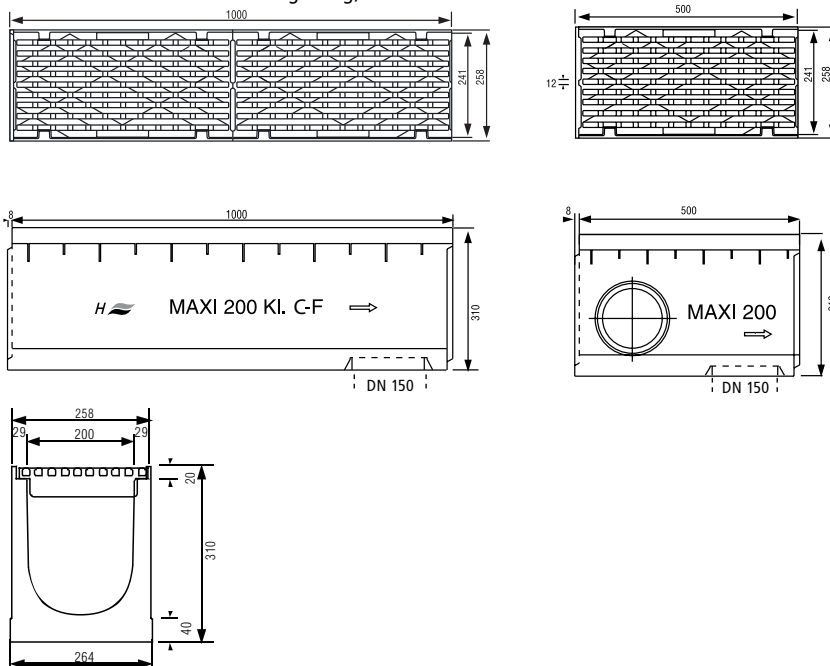

Accessories for all MAXI

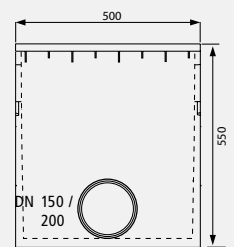

Feed box with galvanised trash bucket

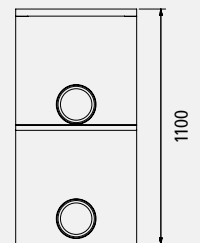

Box drain



Foul air trap
DN 150
item-no.: 7003150

Accessories

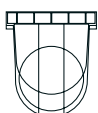

End piece closed
item-no.: 7001200

SYSTEM MAXI⁺ 300

Product description

The new generation in the locking mechanism. The MAXI⁺ with the self-locking system without loose parts. The locking stick and grating are in one, made of ductile iron. All channel sections are supplied with matching gratings pre-assembled.

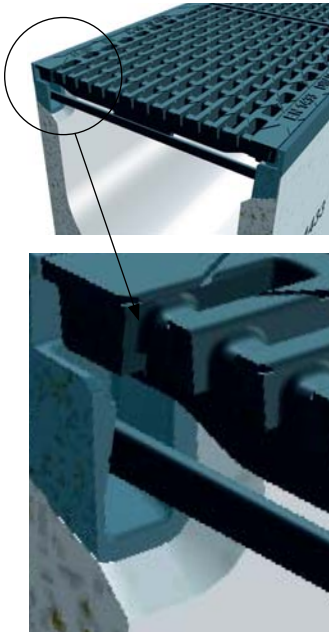

Locking system

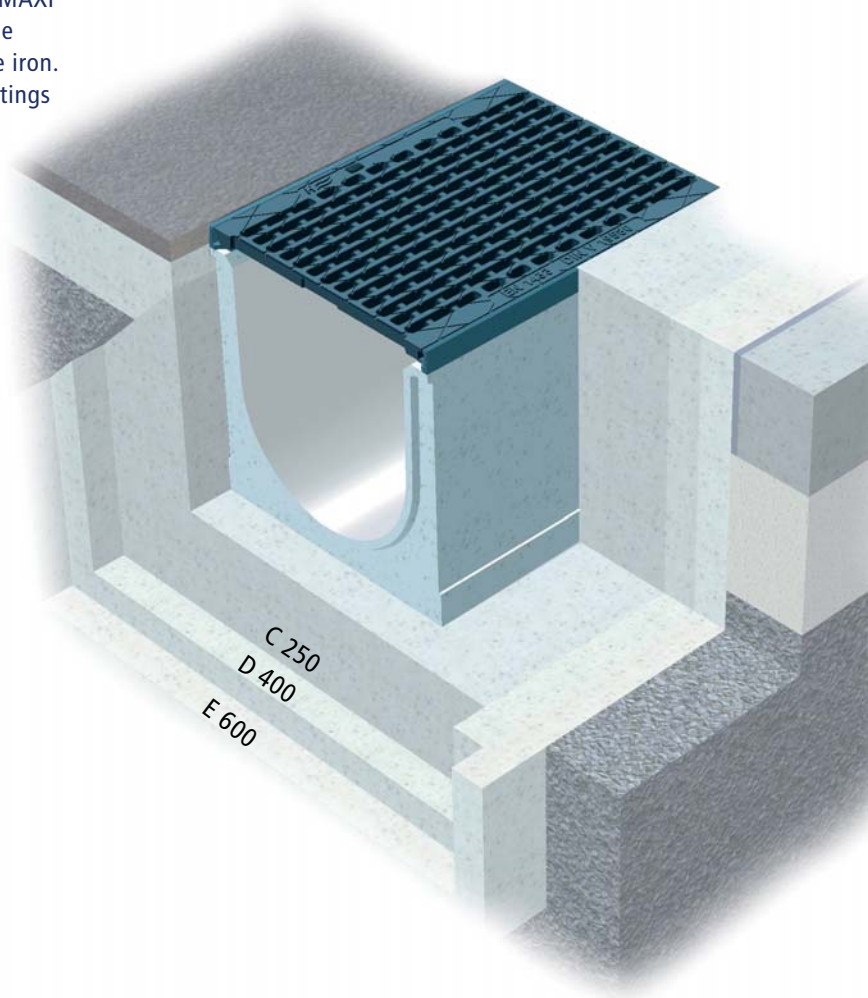

- EN 1433 and DIN V 19580, Typ M
- secure rebated joint
- patented screwless grating locking system
- areas where particularly high wheel loads are expected, e.g. harbour facility

Applications

- **Industry areas with heavy goods traffic**
- **Lorry parking areas / loading and unloading bays**
- **Additional locking positions available similar to "F1" channel**

SYSTEM MAXI⁺ 300

MAXI⁺ 300 E with ductile iron grating and edge protection



	Code E 600	Weight (kg)	Length mm	Effective height (mm)		Pallet
				Inlet	Outlet	
Channel section	66350...					
400	...050	180,0	1000	210	210	6
	...055	90,0	500	260	260	4
Feed box	750	...008	139,0	500	750	4

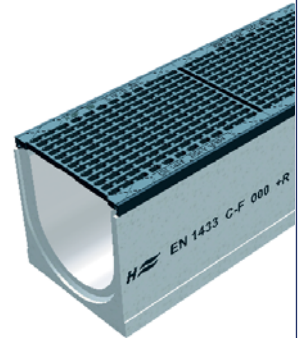

Channel section with 2 slotted gratings, inlet cross section 1.120 cm²/m

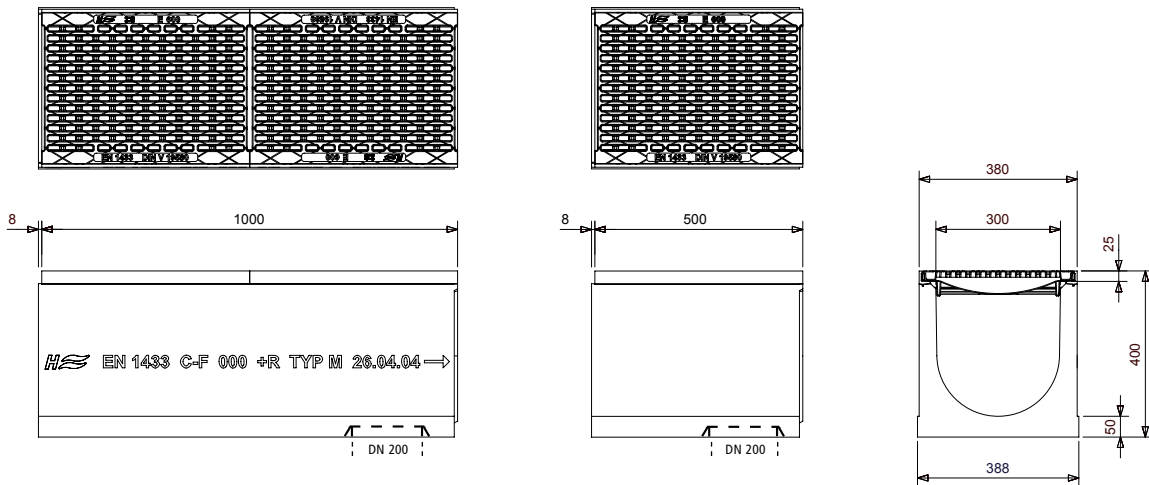

Accessories

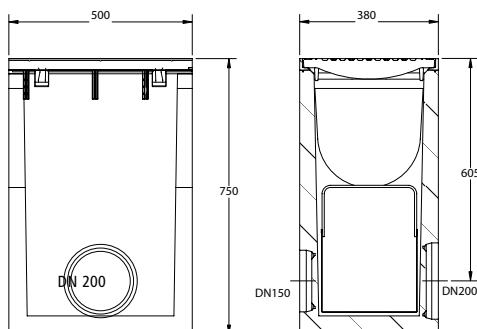

Feed box with galvanised trash bucket

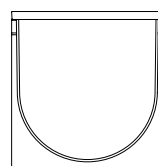

End piece
Inlet item-no.: 7001300
Outlet item-no.: 7001301

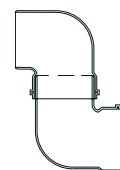

Foul air trap
DN 200
item-no.: 7003200

SYSTEM HYDROblock

Simple. Safe. Watertight. Ingenious. HYDROblock

A revolutionary one-piece drainage system made from ductile iron.

The introduction of the HYDROblock-Drainage Channels has catapulted HYDROTEC Technologies into a new era of drainage systems.

SIMPLE:

The clever but simple design of this unique drainage channel sets new standards as HYDROblock are the only channels on the market manufactured completely from Ductile Iron GGG. Ductile iron by nature is a durable material making it possible to carry the highest load classes with comparatively low weight. It has a very low expansion rate so breakage or cracking of the surrounding concrete bed is avoided. Corrosion of the channel is minimized due to the high quality weather resistant epoxy coating.

SAFE:

HYDROblock channels are user friendly and can be comfortably installed by 1 or 2 men, depending on the classification/weight of product, without the use of heavy machinery. The monolythical design guarantees non-rocking and long term traffic safety. These channels are much simpler to install due to a reduced number of parts and up to 35% less concrete is required for bonding. The channel is ready for use immediately after the concrete hardens.

WATERTIGHT:

The installation process is simplified by the innovative use of the sealing system which has been designed using the principle applied for the manufacture of standard plastic pipes/joints. This system leads to a water-tightness in drainage channels as never seen before. The design with which standard muff couplings can be used, where required, allows for easy handling and correct installation.

INGENIOUS!

Substantial cost savings are made through ease of installation. Ongoing maintenance of the HYDROblock channel is very low and cleaning can be carried out using standard cleaning equipment. The HYDROblock product has up to double the amount of drainage cross section in comparison to other monolythical systems giving a much higher hydraulic performance. Connecting elements are available with horizontal and vertical outlets.

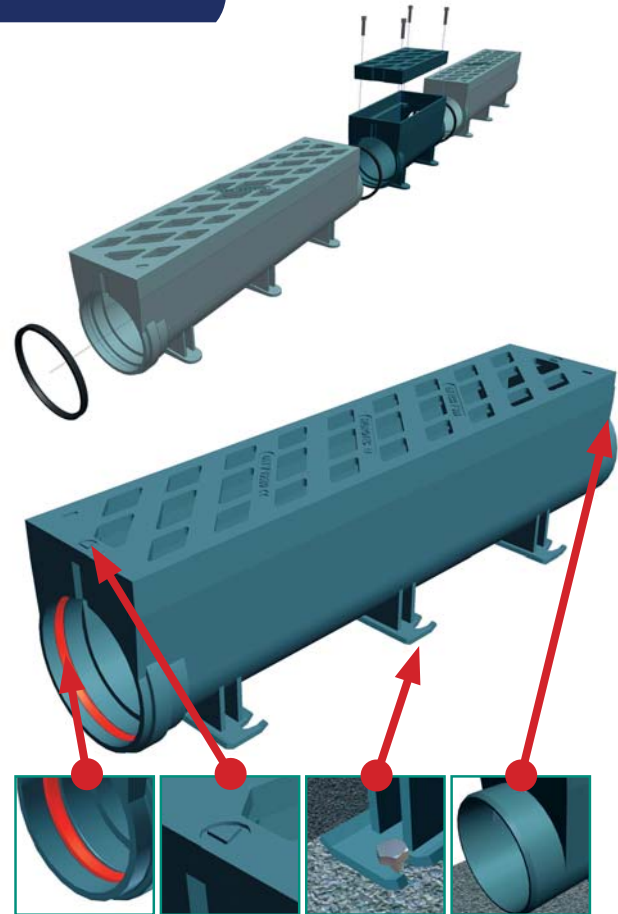

The first channel with built-in sealing ring Flow directional marking Adjustable feet for installation on various foundation beds Long collar for dependable water-tightness

- Minimal demands at planning and installation stages
- constant traffic safety
- low maintenance
- Anti-theft and vandalism protection
- frost-resistant
- low weight for easy handling
- Monolythical design using ductile iron GGG
- Slot design suitable for traffic from all directions
- up to 50% larger cross section than comparable systems

Applications

- Areas with high load traffic and high safety requirements
- For installation where channel crosses the roadway – ie; railway tracks.
- Container terminals and airports
- Loading and un-loading ramp areas ie; transport companies, distribution centres
- Areas where noise or removable parts are not permitted



System complies with DIN EN 1433 channel type I no additional concrete coverage. A load-bearing foundation is required on installation.



HYDROblock is designed to suit all standard plastic (PE and PP) pipes and joints, which when installed complete the system.

SYSTEM HYDROblock

HYDROblock F 900

	Width (mm)	Code	Weight (kg)	Length (mm)	Effective-height (mm)
HYDROblock					
channel section	100	60060050	25	1000	180
Inspection element with vertical outlet		60060058	17	500	180
T-element		60060358	18	500	180
channel section	200	60260050	66	1000	295
Inspection element with horizontal outlet		60260058	42	500	295
T-element		60260358	43	500	295
HYDROblock DRAIN					
channel section with drain opening right	100	60062150	24	1000	180
channel section with drain opening left		60062250	24	1000	180

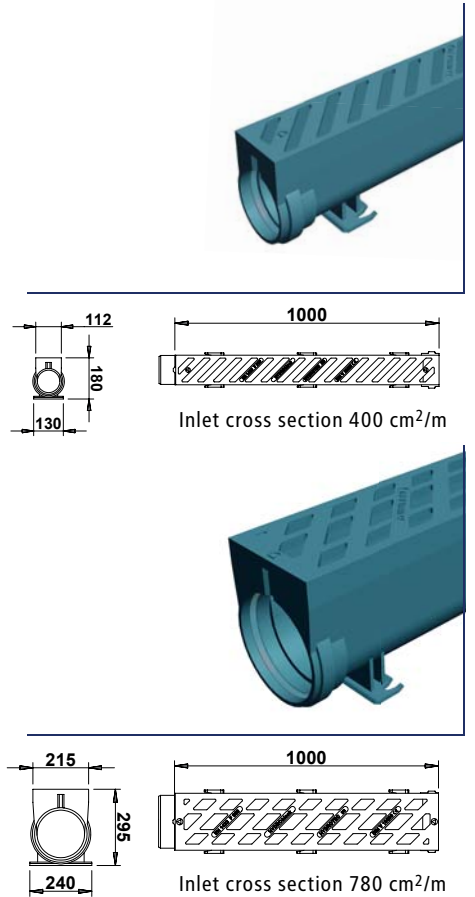

Inspection parts

multi-functional element with vertical outlet



4 point screw down system for no noise and safe entry for inspections



Low maintenance design with stainless steel screws and easy accessible screw holes



Accessories for HYDROblock



Simple design suitable for draining porous asphalt. The sizes of the drain openings have been set to suit standard asphalt layer requirements.



Lifting aid for installation by one person where suitable item-no.: 70009920

T-element with 2 horizontal 90° outflows

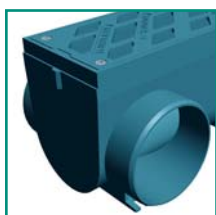

Optional left-and/or right sided outflow to corner or horizontal drainage connections

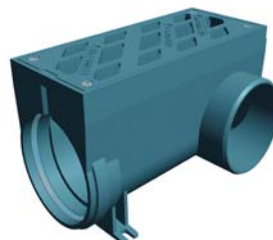

Compatible with all standard plastic (PE and PP) pipes and joints which allows for flexibility at planning and design stages

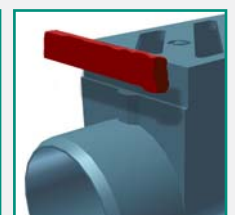

Pre-finished profile for bitumen sealing piece, used where special demands are put on surface water-tightness stages

General Info

Please regard the following principles during installation of the drainage channels: The laying method of the drainage channels depends upon the traffic loads and the planned surface. The installation points are subdivided under EN 1433 into the classes A 15 to F 900. From class C upwards, all gratings must be installed so as to cause no danger to traffic. The base (foundation) for the drainage channels must be designed according to the respective traffic loads.

Horizontal loads due to traffic or thermal reactions of the surface are to be sustained by means of adequate concrete encasement of the channel and by placing expansion joints alongside the channel line, particularly in subsequent concrete surfaces. Joints transverse to the channel line are always to be placed at the endpieces of the channels.

The direction in which the channels are laid always runs against the flow direction and begins at the connecting point to the sewer or at the feed box. Subsequent surfaces are to be placed 3-5mm above the edge protection/grating to accommodate later setting and compacting. Washouts and surface scouring should be prevented through adequate measures.

In cases of extreme horizontal forces transverse to the channel line, e.g. railway crossings, ramps, or on highways, the drainage channels should be secured sideways with approved road concrete.

Type M

We produce our channels beside HYDROblock system according to EN 1433 Type M. This construction needs a base and/or encasement to bear the vertical and horizontal loads. Also see installation advice on page 22 and 23.

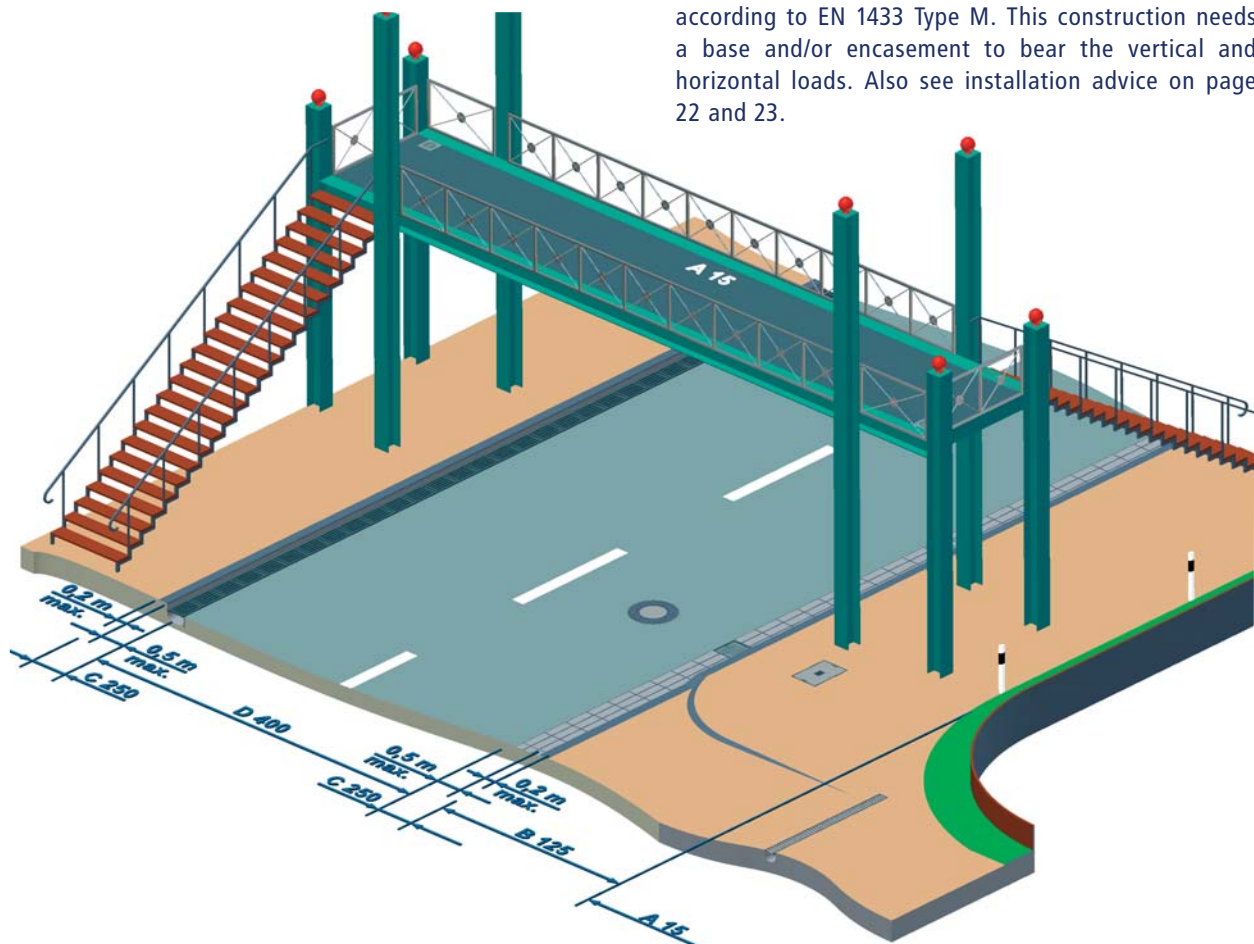

Group 1:
min. class A 15

Road surface which can only be used by pedestrians and cyclists.



Group 2:
min. class B 125

Pavements, pedestrian precincts and similar surfaces, parking areas and parking decks.



Group 3:
min. class C 250

Kerbs and road verges and similar. Kerb slot channels are always group 3.



Group 4:
min. class D 400

Road surfaces (also pedestrian walkways), road verges and parking areas which are accepted for all kind of road vehicles, e.g. highways.



Group 5:
min. class E 600

Road surfaces where particularly high wheel loads are expected, e.g. harbour and dock areas, distribution centres.



Group 6:
class F 900

Surfaces where extremely high wheel loads are expected, e.g. air traffic areas.

INSTALLATION INFO

Vertical channel connection

Various methods of connecting channels to the sewer

All MINI-, TOP- und MAXI-channels have a precast outlet in the base of the channel. The precast outlet can be knocked out with a hammer once you have placed the channel section on wooden supports leaving a space beneath. With the corresponding joints, the channel system can quickly be connected up to pipelines.



Precast outlets in the channel base.
DN 100/150/200.

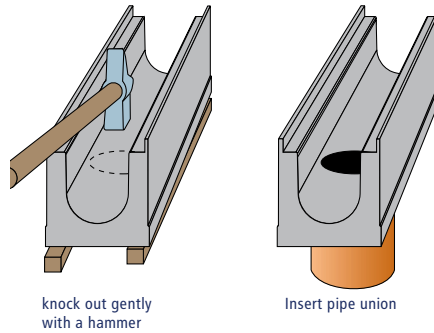

knock out gently with a hammer
Insert pipe union
Matching: the pipe joints.

Setting help for MAXI+ 300

The placing of the MAXI+ 300 is best carried out with the help of a lifting aid.

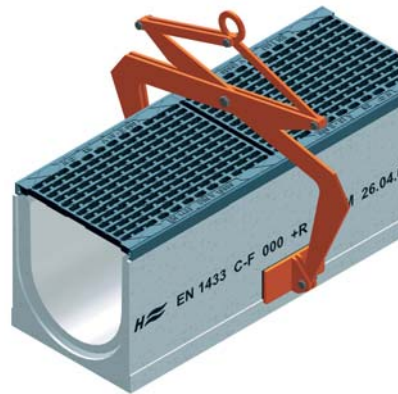

Joint connection at request "liquid tight channel"



INSTALLATION MINI / TOP

MINI 100 - class A 15 / B 125



Example of installation: paved areas

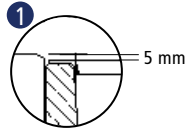

For later settlements and compacting the channel must be placed 3-5 mm lower than the upper surface.

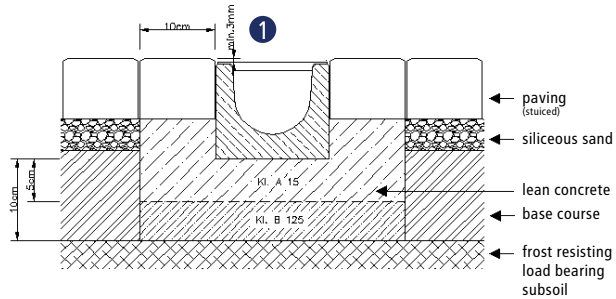

TOP 100 - class A 15 - C 250



Example of installation: asphalt areas

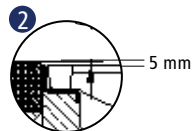

The upper edge of the drainage channel must permanently lay approx. 5mm deeper than the adjoining surface.

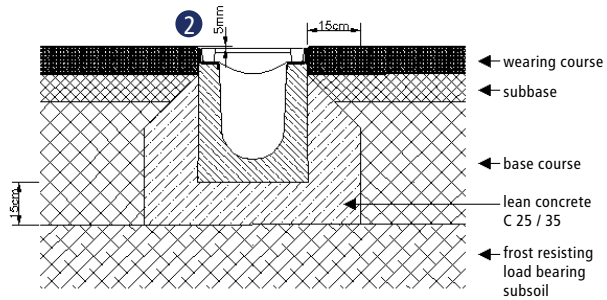

Surface fixing: asphalt / runner stone / kerbstone

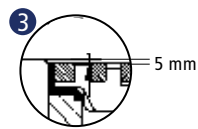

The upper edge of the drainage channel must permanently lay approx. 5mm deeper than the adjoining surface.

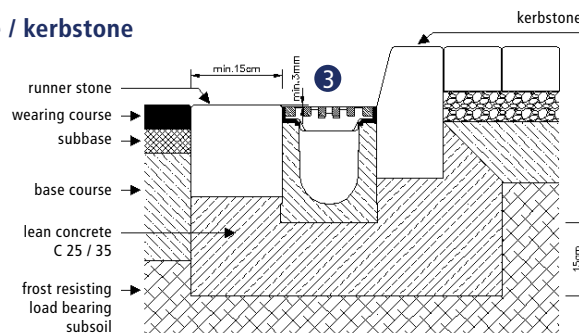

Surface fixing: road concrete / pavement

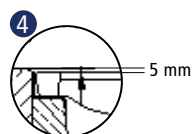

The upper edge of the drainage channel must permanently lay approx. 5mm deeper than the adjoining surface.

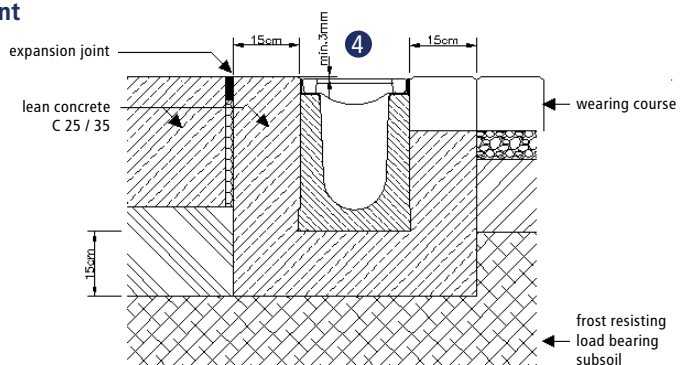

INSTALLATION MAXI 100 / 150 / 200 / 300

MAXI 100 / 150 / 200 / 300 - class A 15 - C 250



Example of installation: paved areas / runner stone / kerbstone

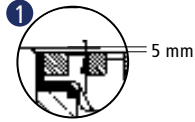

The edge protection of the drainage channel must lay permanently approx. 5mm deeper than the adjoining surface.

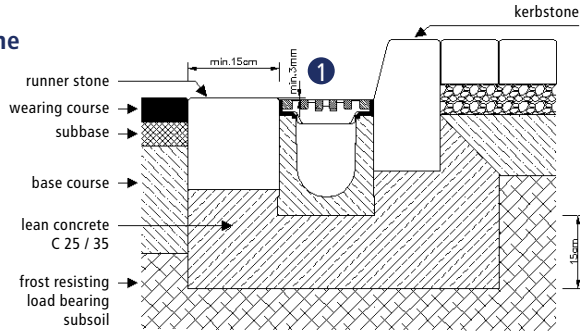

Example of installation: pavement

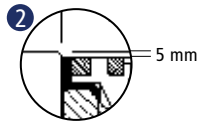

The edge protection of the drainage channel must lay permanently approx. 5mm deeper than the adjoining surface.

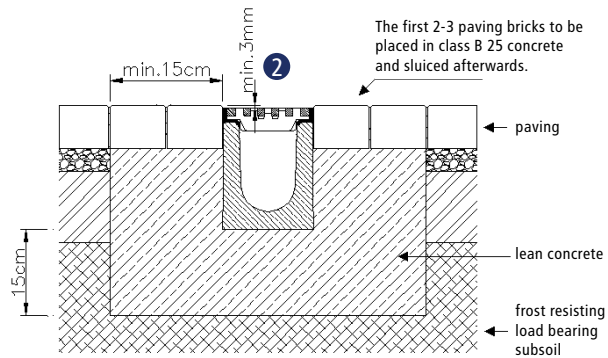

MAXI 100 / 150 / 200 / 300 - class D 400 - F 900



Example of installation: concrete and paving areas

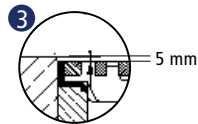

The edge protection of the drainage channel must lay permanently approx. 5mm deeper than the adjoining surface.

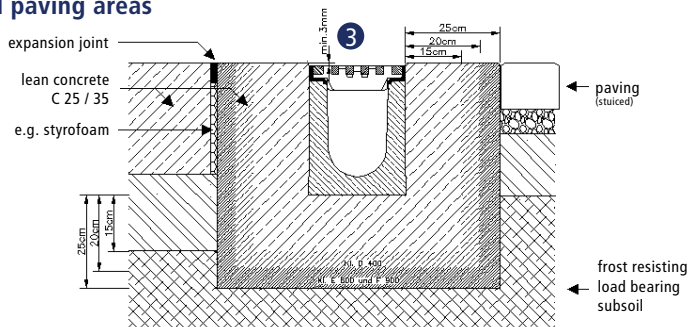

- The concrete strength of the encasement minimum C 25 / 30.
- The edge protection of the drainage channel must lay 3 mm deeper than the adjoining surface.
- The strength of the expansion joint must be adapted to the local conditions.
- At extreme stressed installation points a reinforcement of the encasement is recommended.

MAXI 100 / 150 / 200 / 300 - class C 250 - F 900



Example of installation: asphalt areas

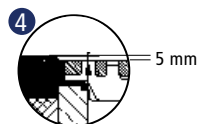

The edge protection of the drainage channel must lay permanently approx. 5mm deeper than the adjoining surface.

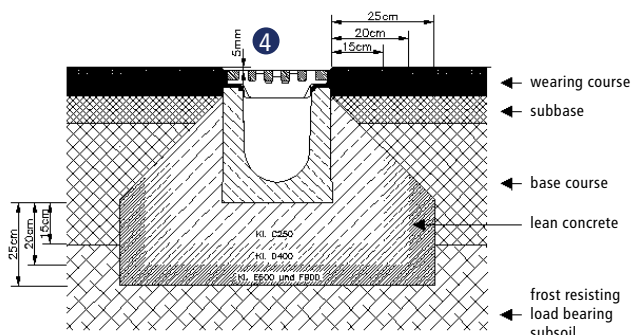

Laying direction

The direction in which the channels are laid always runs against the flow direction (green arrows!) and begins at the connecting point to the sewer or at the feed box. If elements are laid in two different directions, two sections have to be joined up in opposite directions at the point where they meet. To avoid a gap either remove the spigot or use end pieces.

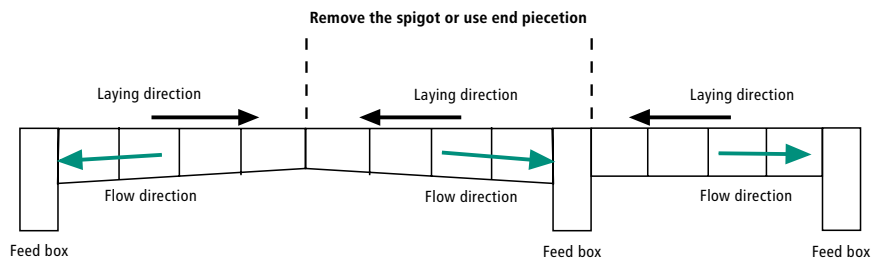

Accessories

System		Code	Weight (kg)	
Assembly rod		7009900	0,65	
Shovel		7009950	1,35	
Sealant	S-PRO3WF grey	7009702	600 ml	
Primer	S-PRIMER3, transparent	7009701	1.000 ml	
Pipe joint (PVC) DN 100		7002100	-	
Pipe joint (PVC) DN 150		7002150	-	
Pipe joint (PVC) DN 150 oval		7002160	-	
Pipe joint (PVC) DN 200		7002200	-	

SYSTEM MAXI F1

High security channel

The line drainage system for applications with extreme requirements regarding different aspects of security.

The assimilation of maximum undertow and brake forces in combination with sufficient fire resistance are requirements on mounting parts in extreme stressed traffic areas.

The cover grating is anchored with the channel through a locking latch and edge protection. Longitudinal slots prevent overflowing water and allow the absorption of double the amount of water

A special screw locking system with screws made of stainless steel:

- easy to maintain, only 2 instead of 4 screws per grating
- centrally arranged, no contamination at the screwing pocket, less corrosion
- through-screw-thread with self cleaning system

The sum of the material and construction advantages were precondition to meeting the high security requirements for the formula 1 race tracks in Shanghai and Istanbul and led last but not least under the aspect of profitability to the application of the MAXI F1-channel.



Istanbul



Shanghai



F1 - Circuit Shanghai

MAXI F1 100 / 150 / 200, EN1433, DIN V 19580

Length:	1000 mm	Class:	D400 - F900
Width:	100 mm / 150 mm / 200mm	Inlet cross section:	512 cm ² / 736 cm ² / 970 cm ²
Height:	on request	Construction:	slope according to DIN

Each channel is made of fibre-reinforced as well as frost thawing and salt resistant concrete C 35 / 45 with end-to-end edge protection made of ductile iron.

- 8 interlocking points per running meter
- 2 gratings made of ductile iron with longitudinal slots (12 mm interspace)
- roadworthy, special screw locking system of the cover gratings
- 4 special screws per running meter and 8 interlocking points per running meter
- CE-conformance
- secure anchoring prevents "outgrowing"
- preformed parts for easy assembling of the sections
- secure rebated join for optional sealing according to "WHSG"
- precast base for vertical outlet DN 100 / 150

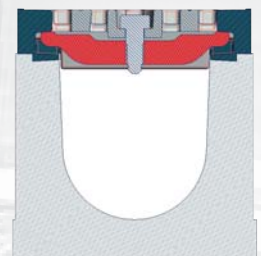

Special Applications

Rail drainage system MAXI 150

Track width 143,50 cm and 100 cm

Track width 143,50 cm = 500mm-section MAXI 150 class D400-E600
(track width 100,00 = only 1 500mm-section MAXI 150 class D400-E600)

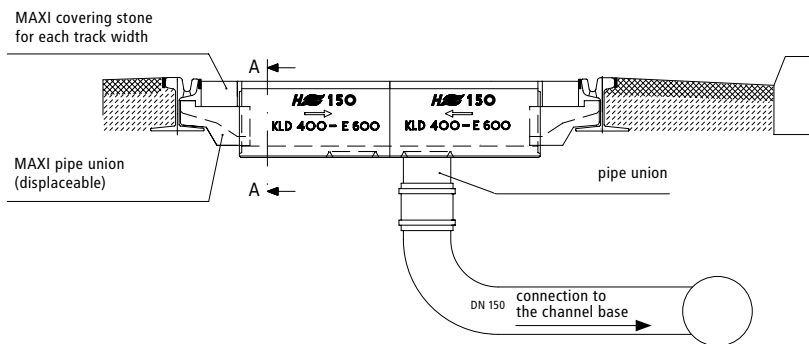
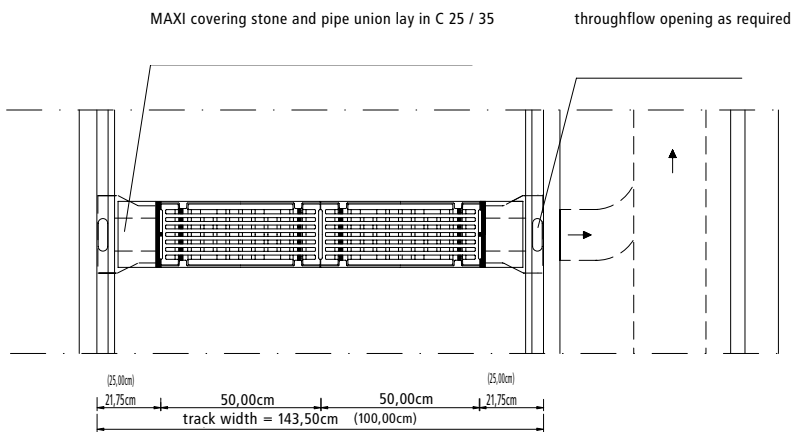

Box drain system TOP 100 / MAXI 100 / 150 / 200

These box drains, developed for channel and point drainage, are particularly applicable for the connection to deeper lying pipes and/or local infiltration into deeper beds.

- integrated dirt trap
- screwless locking
- precast outlet DN 100 / 150
- loading class A 15 bis F 900
- different cover types from galvanised steel gratings to iron gratings
- easy handling thanks to division in two parts

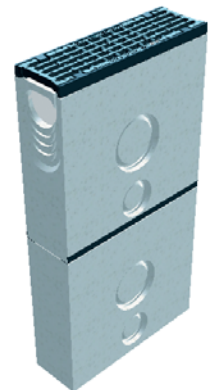

Special Applications

Drain channel system MAXI 100 / 150 / 200

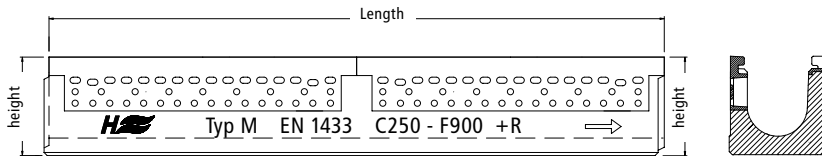

Installation example

MAXI 100 class C250 - F900

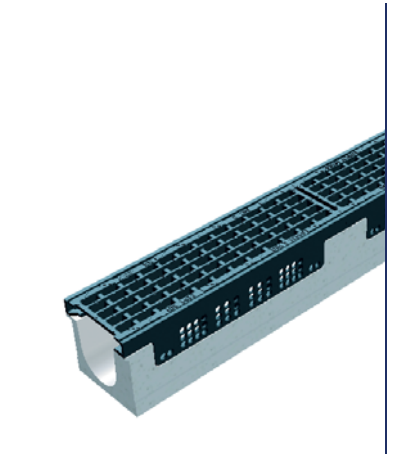
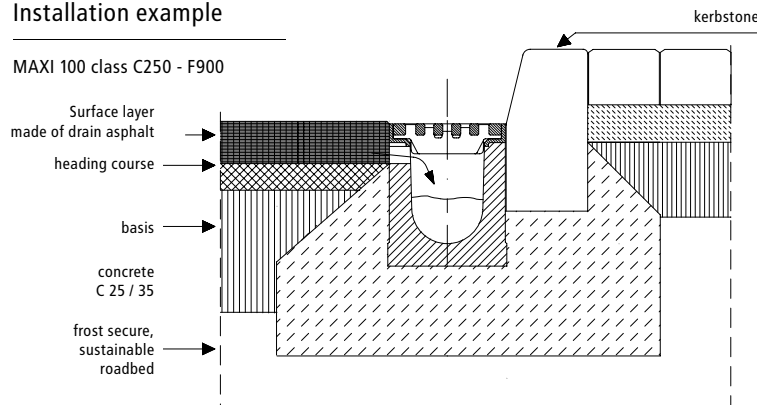

Top frame MAXI 150

For the later installation of the final surface layer.
The solution for the 2-phasing installation.

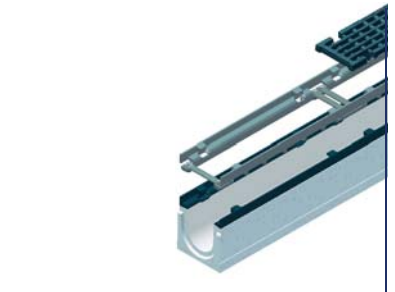
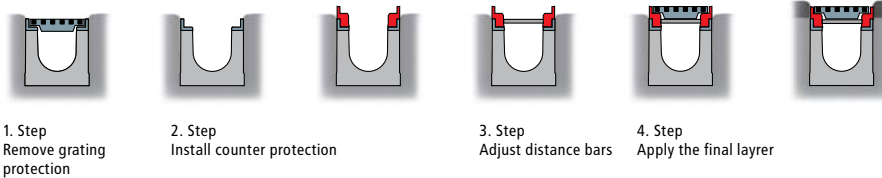

Cable channel system MAXI 150

- with inner separator
- no stumble danger
- loading class C 250 – F 900
- screwless patented fixing of the gratings
- secure anchored edge protection made of ductile iron
- channel made of fibre-reinforced concrete C35/45

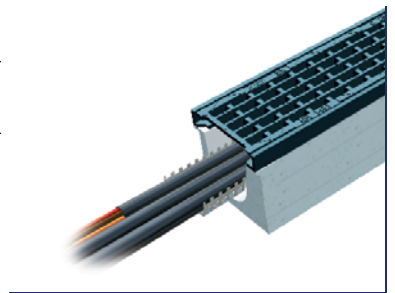
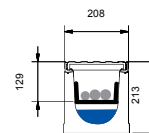
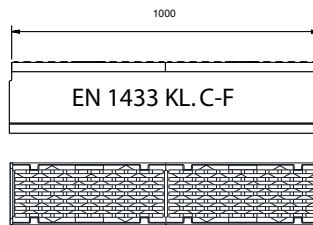

Slotted channel system MINI 100

Top with a sideways or central slot.
Optimal for inconspicuous drainage of paved areas and for facade drainage.

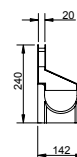
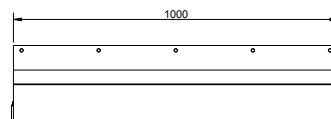

The slotted top is galvanised or made of stainless steel for the loading class B 125.

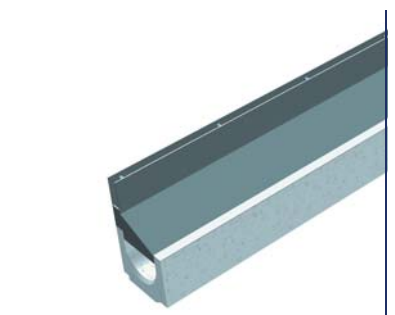
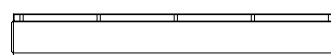

Hydraulic calculations

Catchment depth

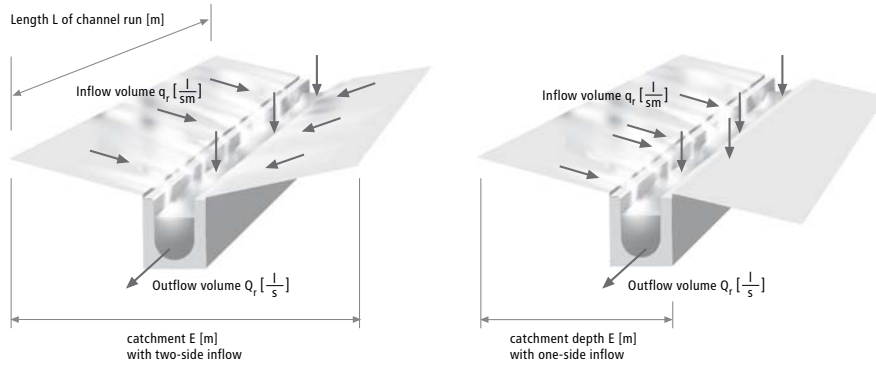

Outflow Volume / Water Level / Base Formation

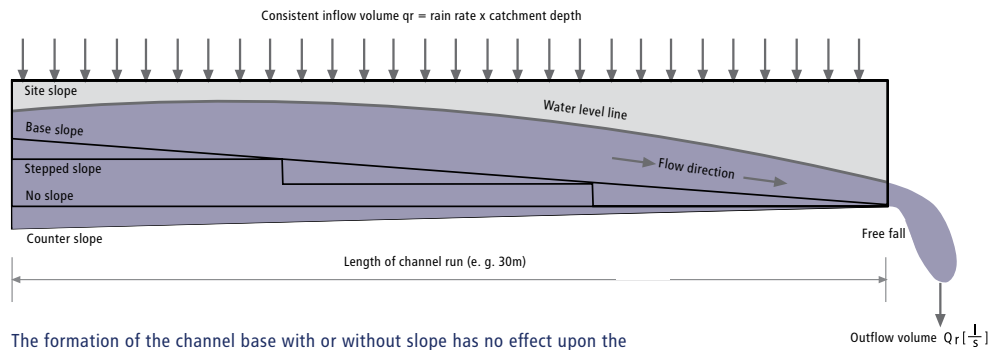

The formation of the channel base with or without slope has no effect upon the outflow volume of the channel run. The water level always takes the same line.

The outflow volume is determined only by the inner channel diameter at the end of the run, the slope has no impact at all.

Result: Less effort without slope.

Calculation of the maximum length of the channel run

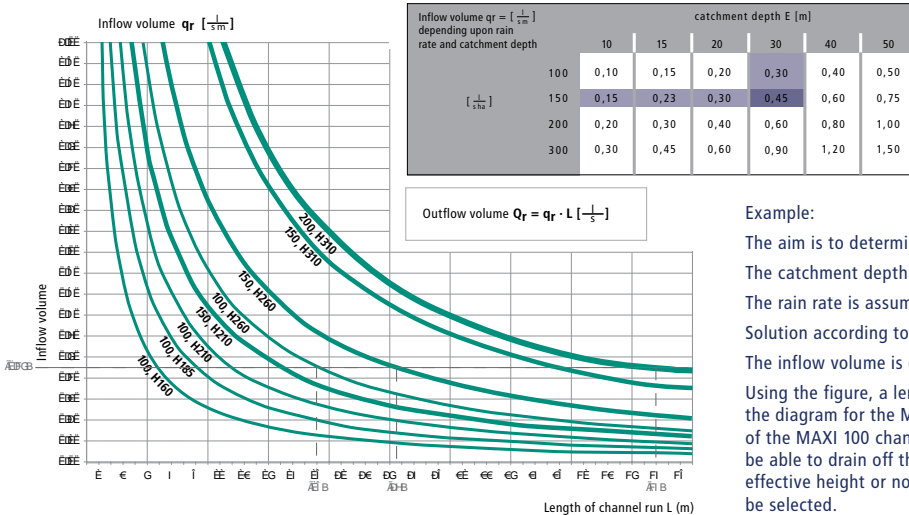

Example:

The aim is to determine length L of a channel run.

The catchment depth E is 30m

The rain rate is assumed as being $150 \frac{1}{s ha}$

Solution according to Chart 1:

The inflow volume is $q_r = 0,45 \frac{1}{s m}$

Using the figure, a length $L = 19m$ can be taken from the diagram for the MAXI 100 channel. If the length of the MAXI 100 channel exceeds 19m, it will not be able to drain off the intake of water. A greater effective height or nominal width would then have to be selected.

For MAXI 150, the length $L = 26m$ and for MAXI 200 $L = 47m$

Outflow Capacity "Q" for the Sewer

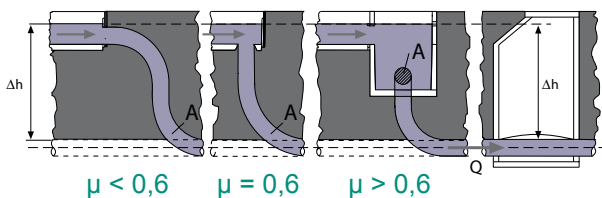

Outlet pipe	A [dm ²]	Outlet volume Q [l/s]			Δh [m]
		0,35	1,00	2,00	
100	0,85	13,4	22,6	32,0	μ
150	1,82	28,6	48,4	68,5	
200	2,87	45,1	76,3	108,0	

$$Q = \mu \cdot A \cdot \sqrt{2g \cdot \Delta h}$$

Certificates



General Points

Pictures, measurements and weights are non binding. All rights to further construction development and alterations to the production process with regard to technical aspects are reserved by HYDROTEC.

All details regarding standards and marks of conformity correspond to those at time of print.



Chrisim Instal SRL
Calea Manastur, Nr. 84/52
400372 Cluj-Napoca

Telefon
+40 722 - 21 56 06
Telefax
+40 264 - 42 01 92
E-mail
office@chrisim-instal.ro
Internet
www.chrisim-instal.ro